

# Lecture #7

## Electronics Intro

### Aims:

- Know the working principle of all electronic components inside a microfluidics workstation
- Understand how they are interconnected to form a useful instrument for bio-analysis

# Question during practical session on 553nm beam splitter

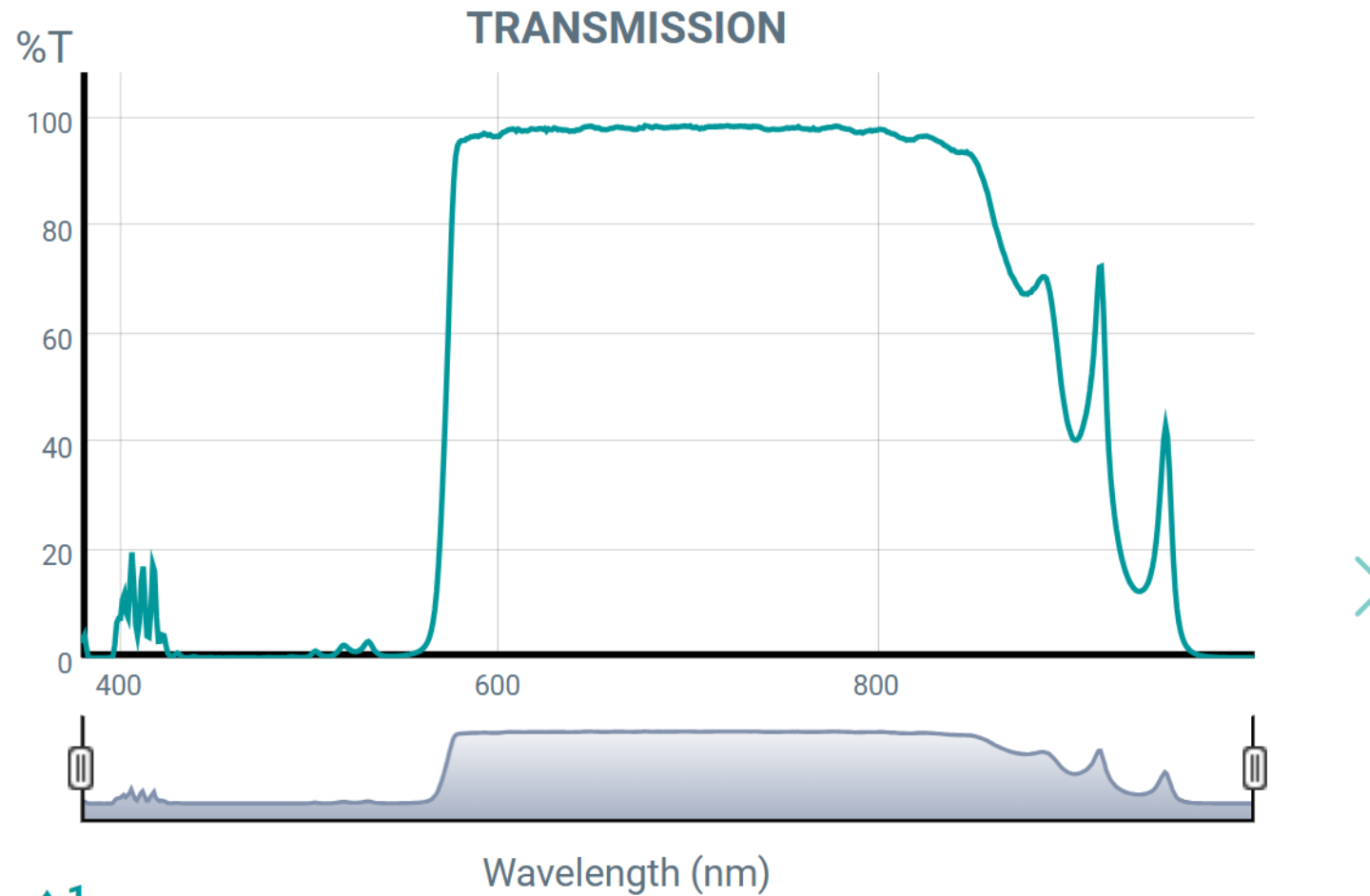

<https://ahf.de/en/products/photonics/optical-filters/beamsplitters/laser-beamsplitters/super-resolution/2-mm-thick-beamsplitters/laser-beamsplitter-zt-561-flat/F48-553>

Lectures (PHH 331)	Date & Topic	Details	Practical
1	12.09 General Intro	Get to know teachers, TAs, students and aims of the course	16.09 Measure temperature using thermistor (using M&A explorer) TL
2	19.09 Lecture LabVIEW TL Group formation (4 students, each)	Some first basic steps in LabVIEW programming	23.09 Brief intro into LabVIEW thermistor program (input and output) TL
3	26.09 Case study FACS, similarities and differences to droplet microfluidics Selection of case study topics	1.) Property to measure? 2.) Device? 3.) Working principle? 4.) Alternatives?	30.09 Preparation of bioinstrument case study
4	03.10 Preparation of bioinstrument case study		07.10 Tour through LBMM workstation labs, intro into Nature Protocols (all groups)
5	10.10 All groups presenting case study		No practical
6	17.10 Lecture optics Homework: Students to prepare one laser/PMT blueprint (by 21.10 23.59h)	Mirrors, filters, microscope setup, lenses, etc.	21.10 Holidays
	24.10 Holidays		28.10 Build workstation optics 1
7	31.10 Lecture electronics	FPGA, PMTs, amplifier, function generator	04.11 Build workstation 1 optics 2, laser alignment
8	07.11 Intro into enzyme concentration measurement experiment (kinetics, etc.) + task FP	Enzymes, kinetics, practical task	11.11 Build workstation electronics
9	<del>14.11 Intro to droplet analysis software (LabVIEW) TL</del>	Software similar to Thermistor program, pdf on installation	18.11 Build workstation software: Add output LED (mimicking sorting trigger) into analysis software
10	21.11 Fundamentals of microfluidics and microfluidic chips	Flow at the microscale, microfluidic chips (manufacturing), droplet microfluidic modules	25.11 Run microfluidic experiments, e.g. determine concentration of MMP in droplets
11	28.11 Prepare presentation		2.12 Sorting Demo on LBMM workstation1 (Groups A&B)
12	05.12 Groups presenting results (A-C not present)		09.12 Sorting Demo on LBMM workstation1 (Groups C&D)
13	12.12 Groups presenting results (D-F not present) 15.12 Submit report (all!)		16.12 – TUESDAY! - Individual Q & A sessions (10min, each)

Green shading: Single seminar/practical with all 18 students  
Red shading: Individual seminar/practical with only 6 students required (= 3 sequential 90min slots, 4.5h in total)

# Electronic components of the workstation

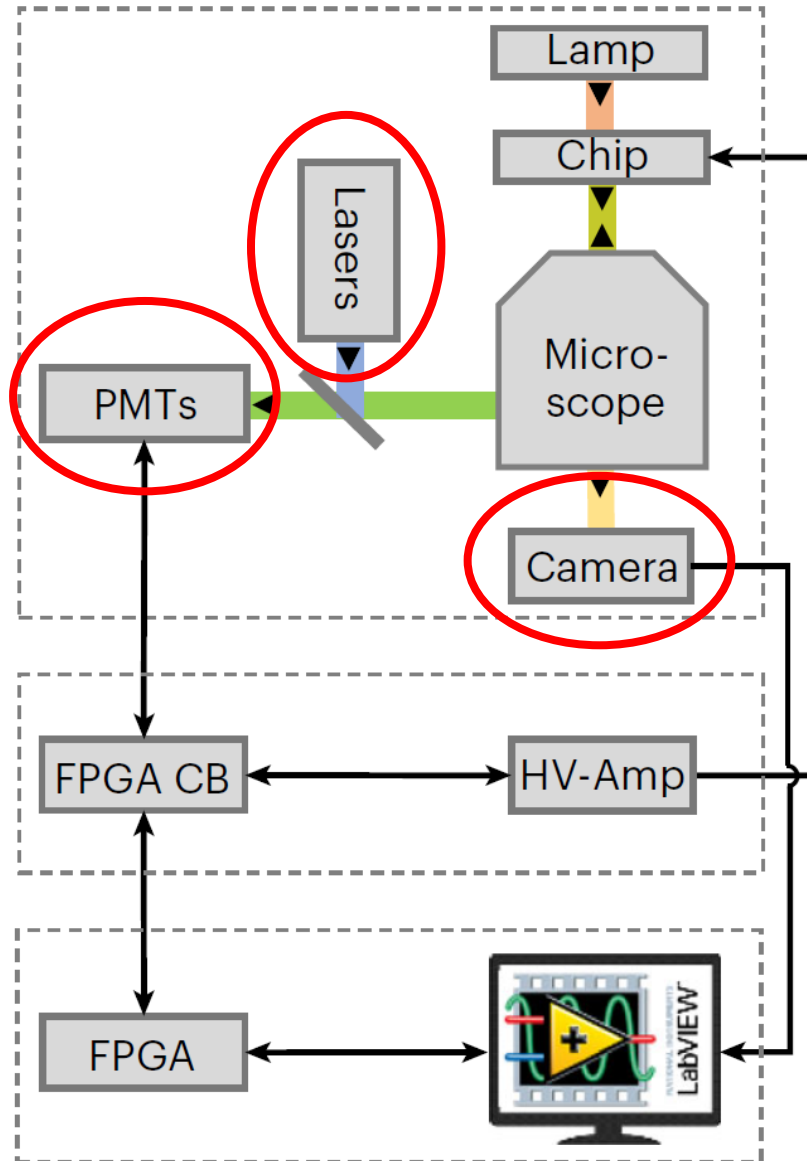

Any idea on how these components work?

# How a laser works

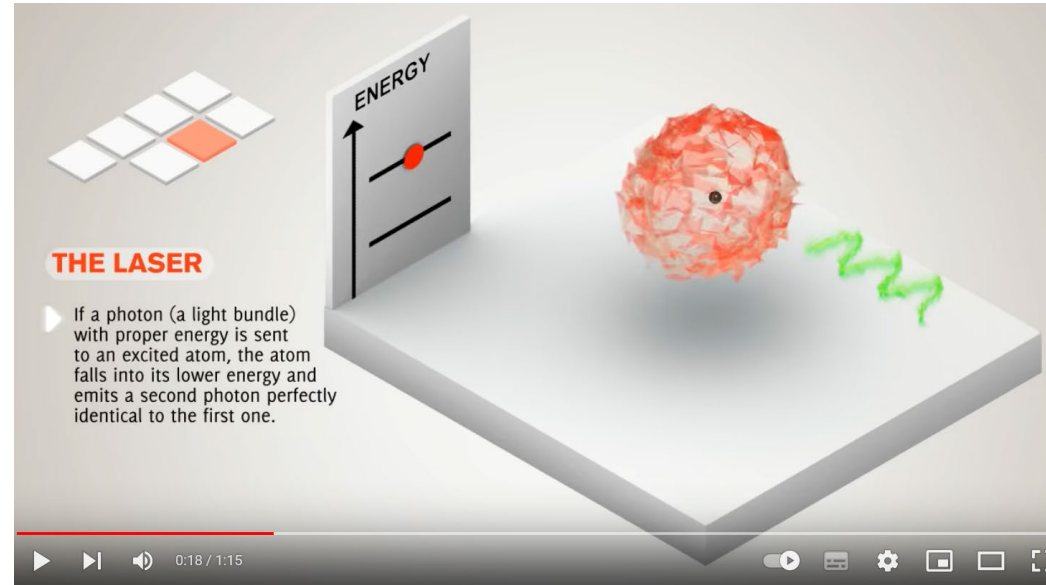

[www.youtube.com/watch?v=R\\_QOWbkc7UI](http://www.youtube.com/watch?v=R_QOWbkc7UI)

In between two semi transmissive mirrors, an optical cavity is generated. First photons are generated by spontaneous emission, causing the generation of other photons by stimulation (all in phase).

# Optical pumping

<https://lasers.llnl.gov/education/how-lasers-work>

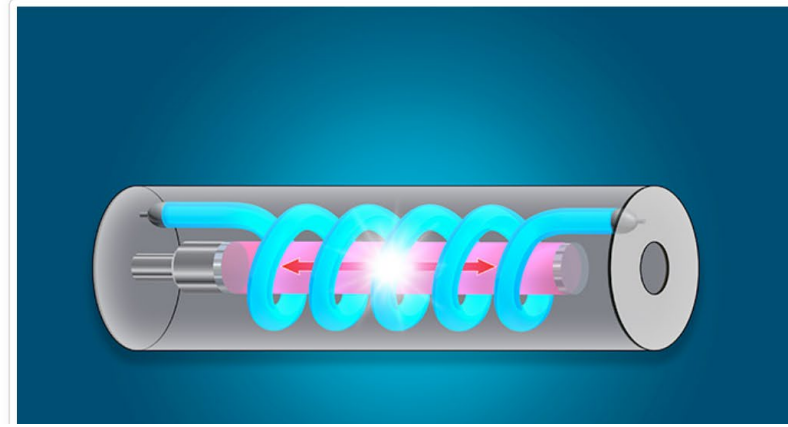
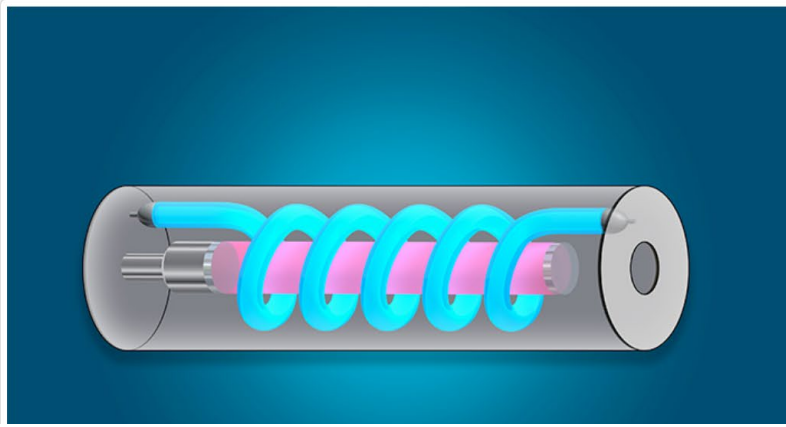

**Laser pumping** refers to introducing energy into a laser system to produce a population inversion, where (in the gain medium) there are **more atoms or molecules in an excited state than in the ground state**. This increases the probability of stimulated emission of light and enables lasing to occur. (www.coherent.com)

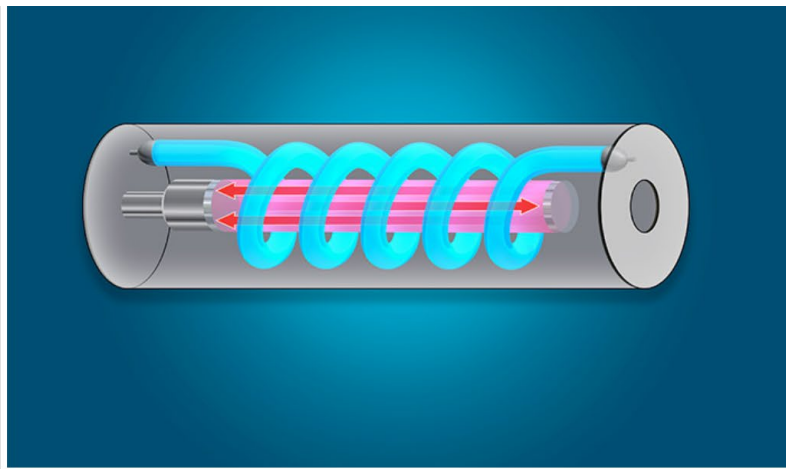

**3.** The photons strike the atoms, creating more and more photons bouncing back and forth between the mirrors within the rod. ↗

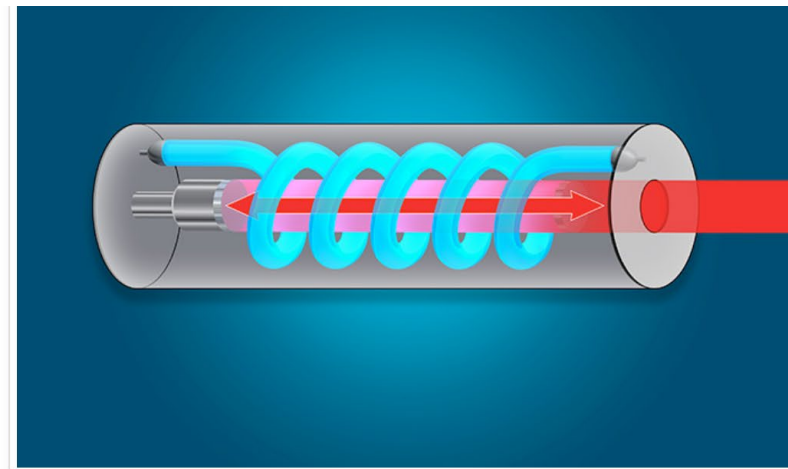

**4.** The number of photons become so great that they pass through one of the mirrors, which is partially reflective, and the laser beam emerges. Credit: Mark Meamber and John Jett ↗

# Electrical pumping

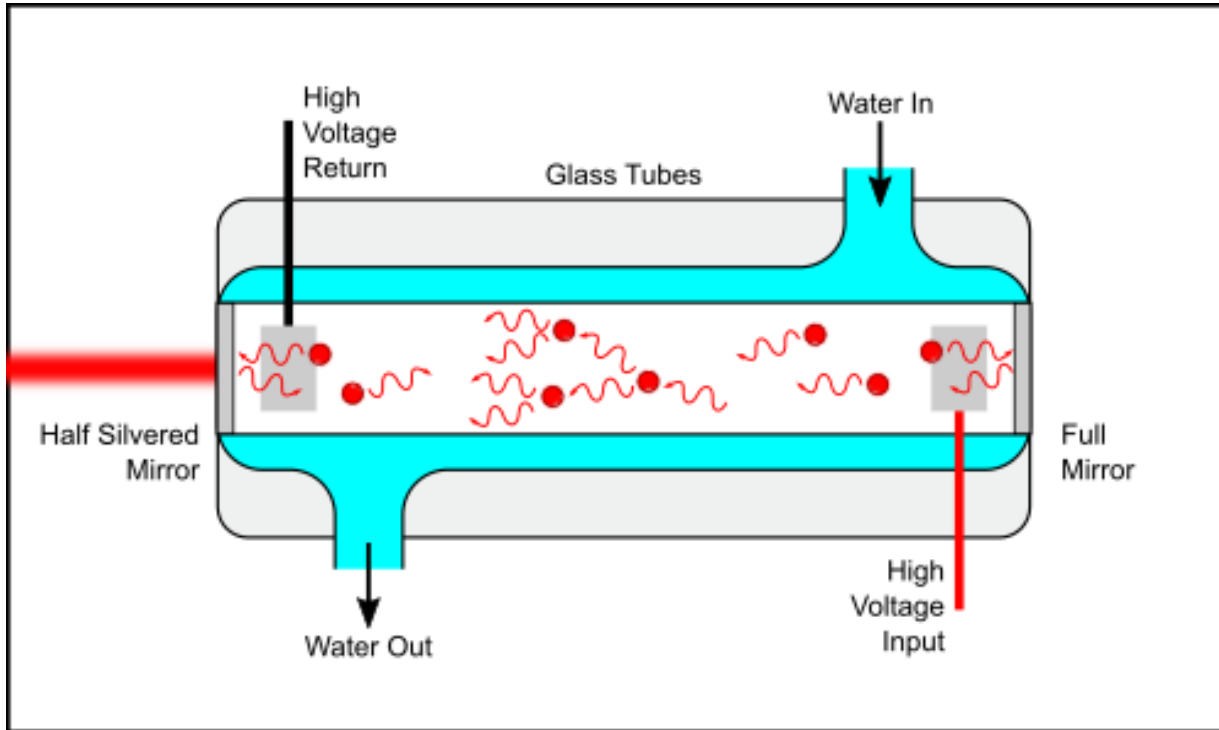

<https://lasergods.com/glossary/laser-pumping/>

gas laser

Wiki image

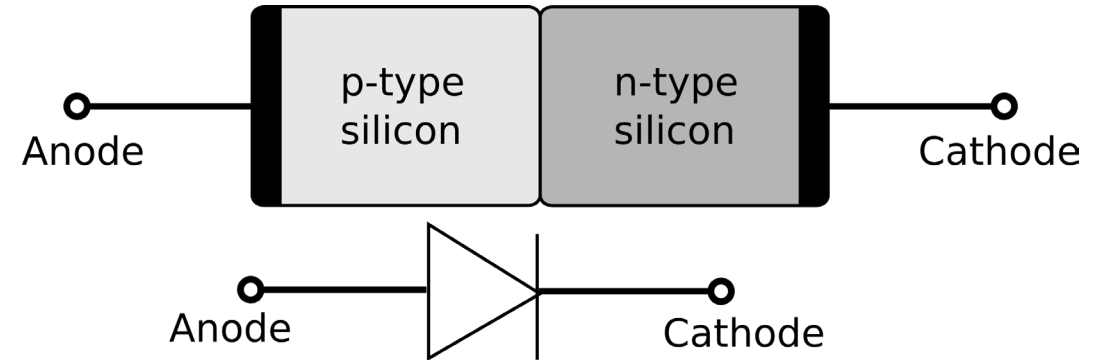

A p-n junction is a boundary between two types of semiconductors, where the p-type semiconductor has an excess of positively charged holes, and the n-type semiconductor has an excess of negatively charged electrons. When a **voltage is applied across the p-n junction**, electrons and holes are injected into the semiconductor, **creating a population inversion and resulting in laser light**.

(www.coherent.com)

semiconductor laser

# Working principle of a PMT

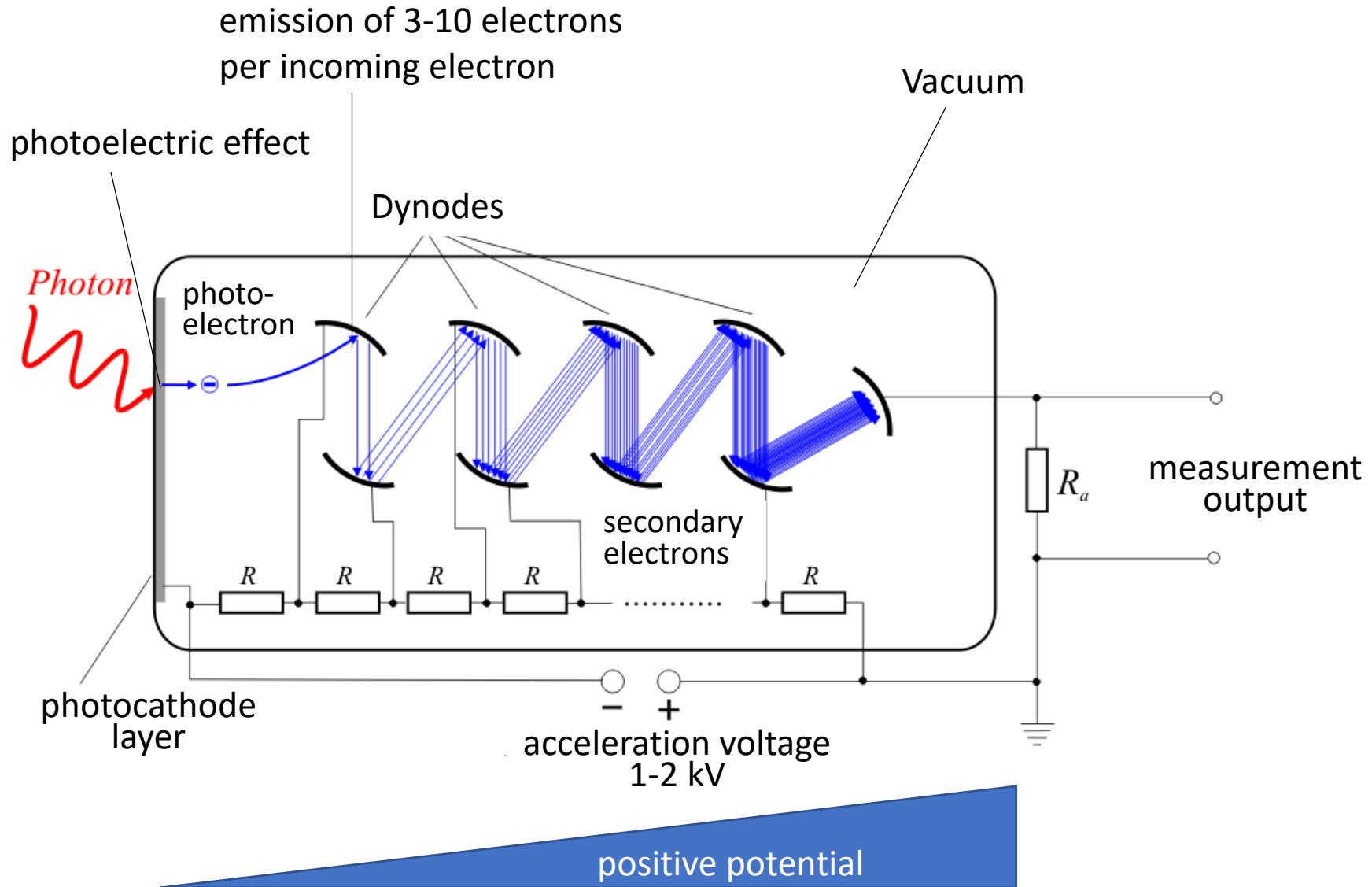

Can conceptually detect single photons!

# PMTs used here

Hamamatsu H11903 series

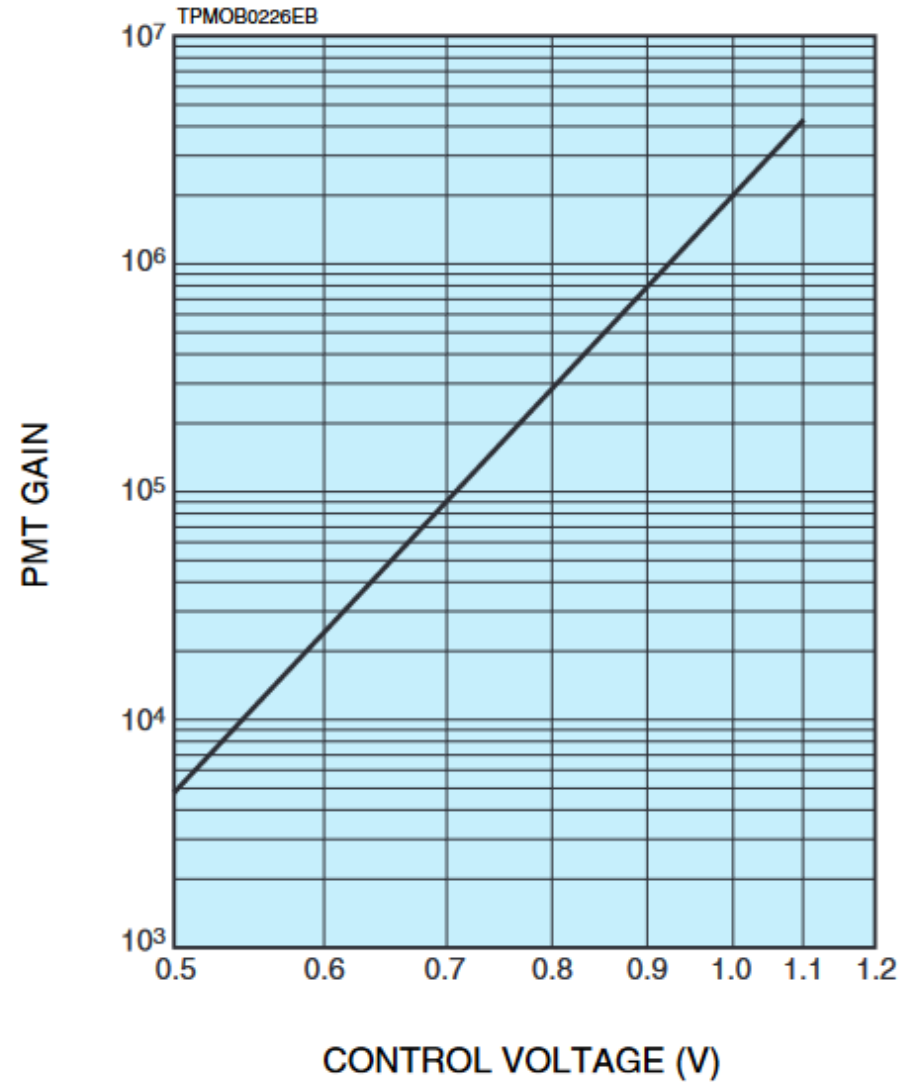

Signal amplification (gain) increases exponentially with control voltage

# PMTs used here

## Group A&B (473nm laser)

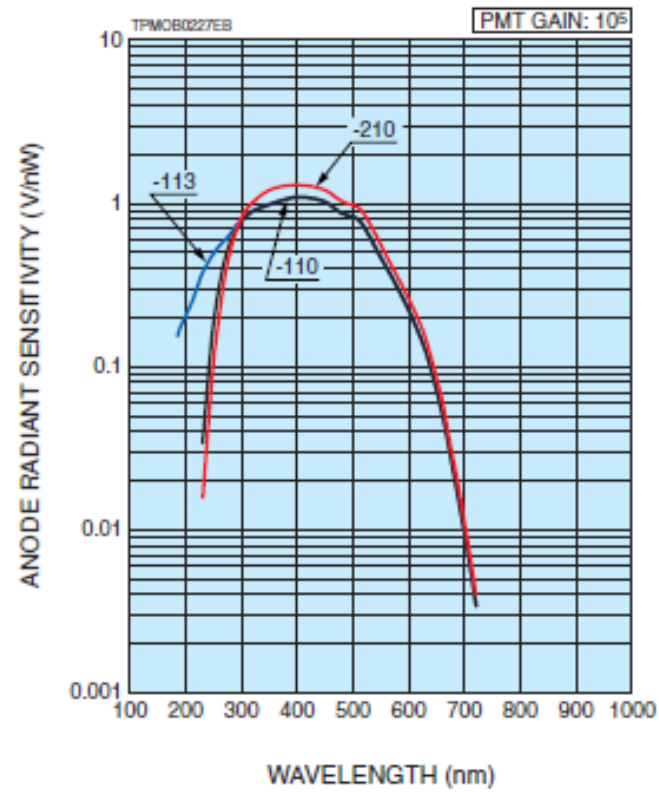

## Group B&D (561nm laser)

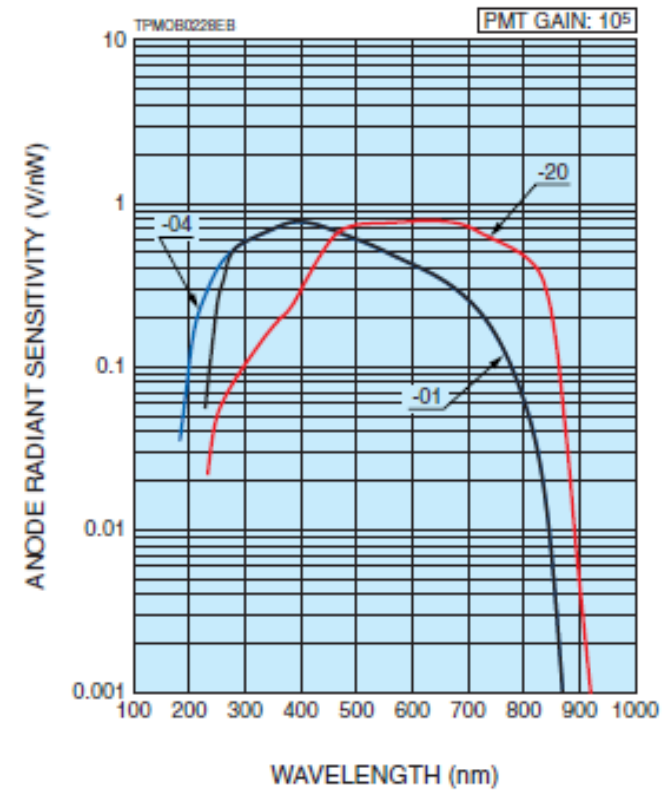

From Hamamatsu datasheet

# Connection of the PMTs – original layout

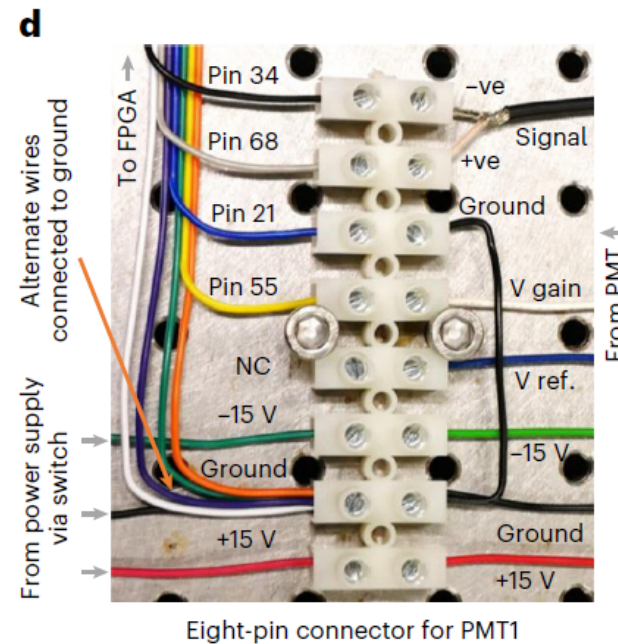
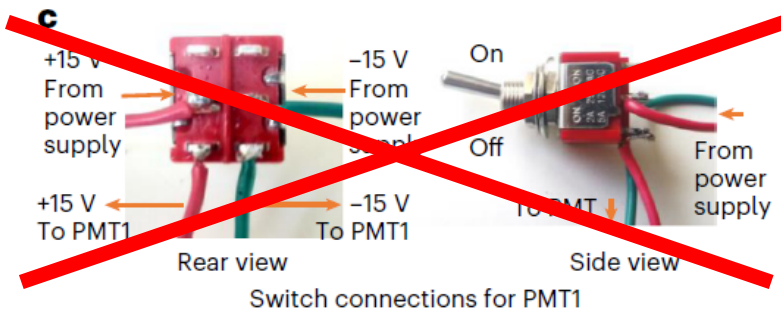
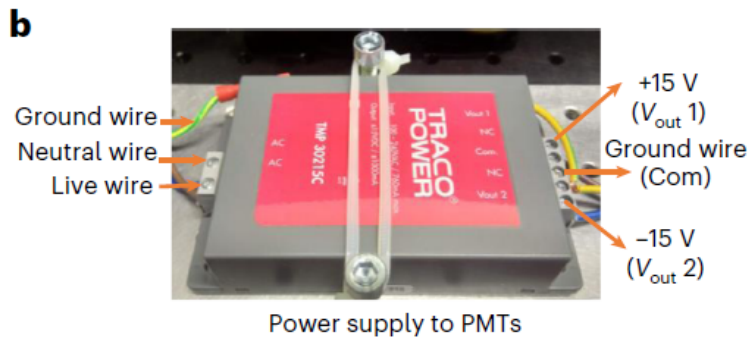
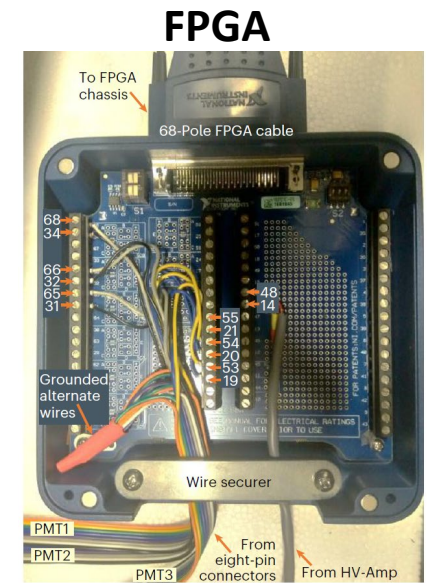
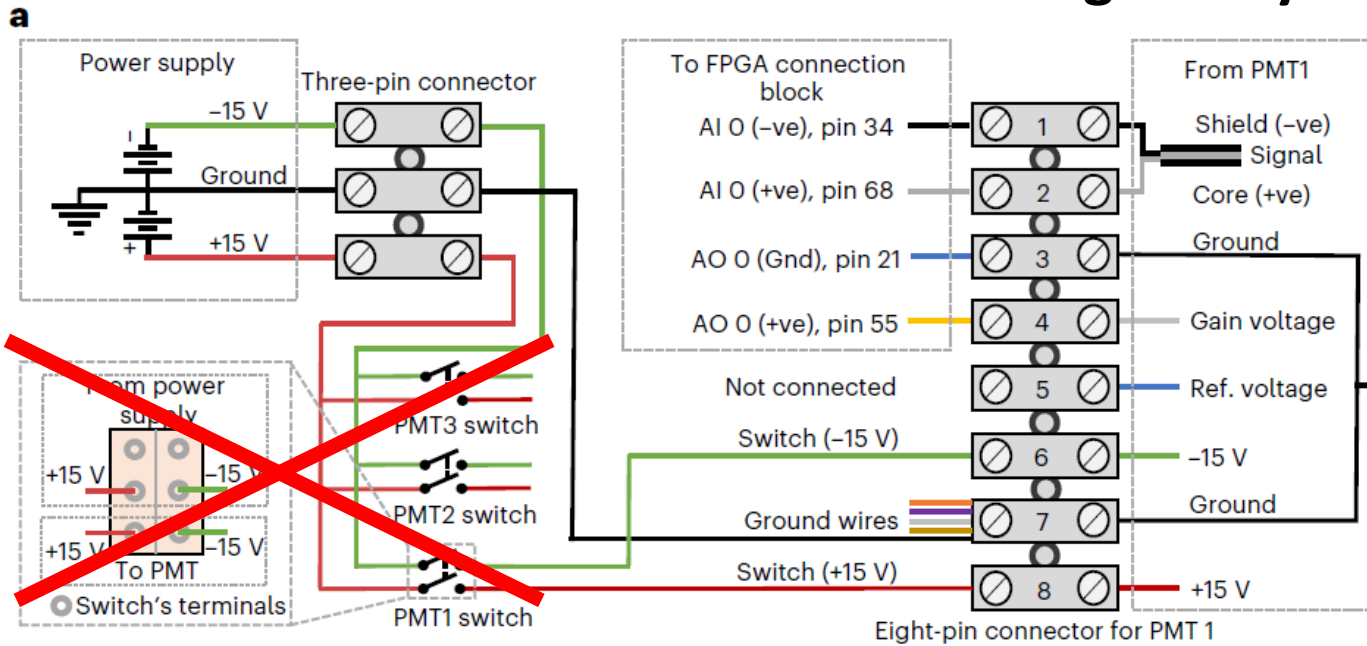

# Connection of the PMTs

Left setup PMT signal  
Right setup PMT signal  
  
Left setup PMT gain  
Right setup PMYT gain

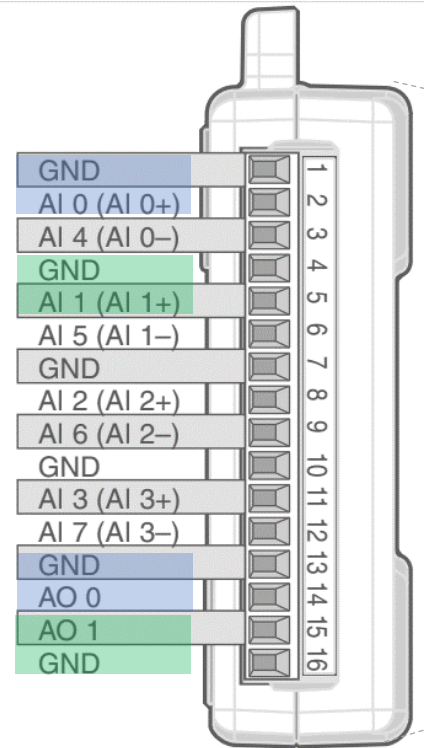

Analog input (AI) and output (AO) channels  
[GND: Ground]

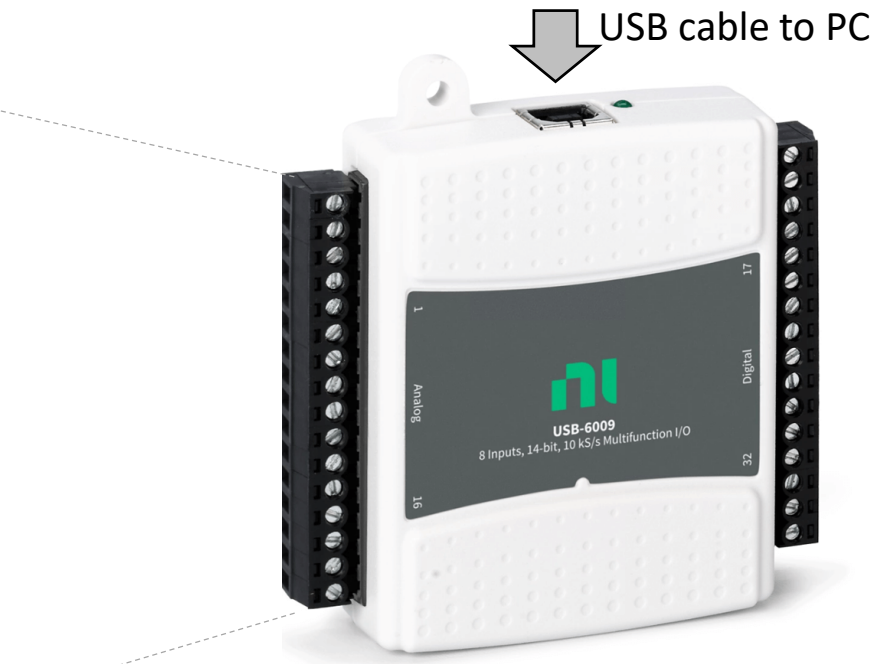

**NI-DAQ (USB-6009)**

A device to establish communication between physical sensors (temperature, pressure, force, torque, stress, photons etc.) and the computer software.

# Connection of the PMTs – course layout



Left setup

- AI 0 (Gnd), Pin 1
- AI 0 (signal), Pin 2
- AO 0 (Gnd), Pin 13
- AO 0 (signal), Pin 14

Right setup

- To Nidaq**
- AI 1 (Gnd), Pin 4
  - AI 1 (signal), Pin 5
  - AO 1 (Gnd), Pin 16
  - AO 1 (signal), Pin 15
- From PMT**
- Shield (-ve)
  - Signal
  - Core (+ve)
  - Ground
  - Gain voltage
  - Ref. voltage
  - 15 V
  - Ground
  - +15 V

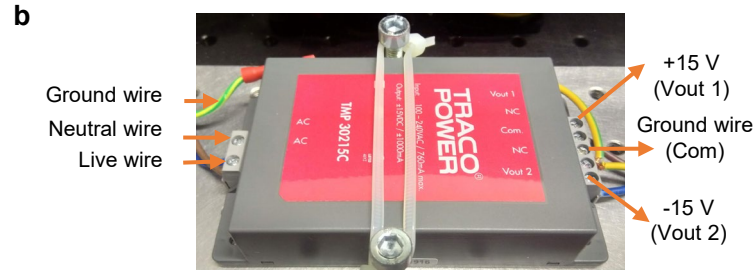
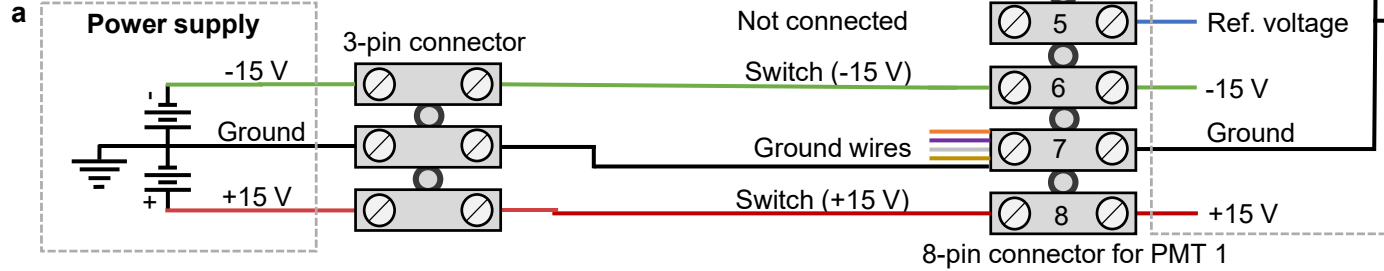

Power supply to PMTs

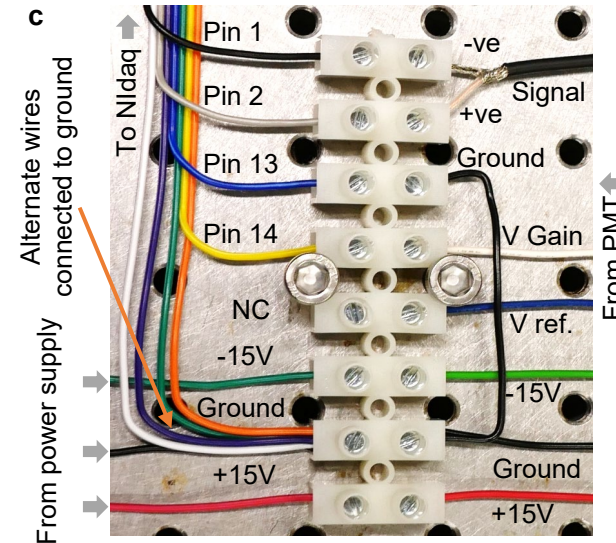

8-pin connector for PMT1

# How digital cameras work

photoelectric effect

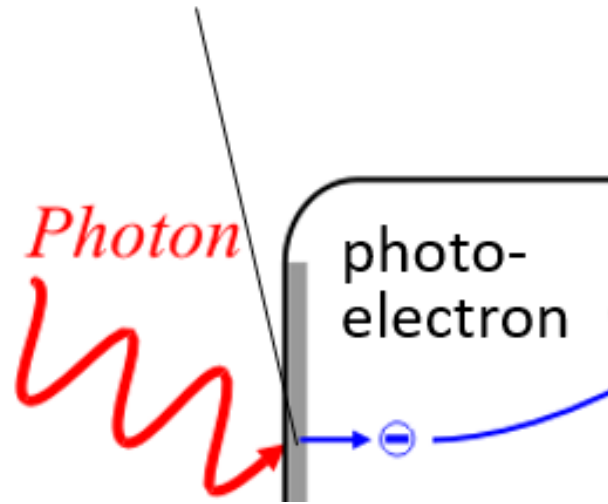

Remember from PMT and imagine a camera as an array of spatially-addressable pixels in which the photoelectric effect takes place!

# How digital cameras work

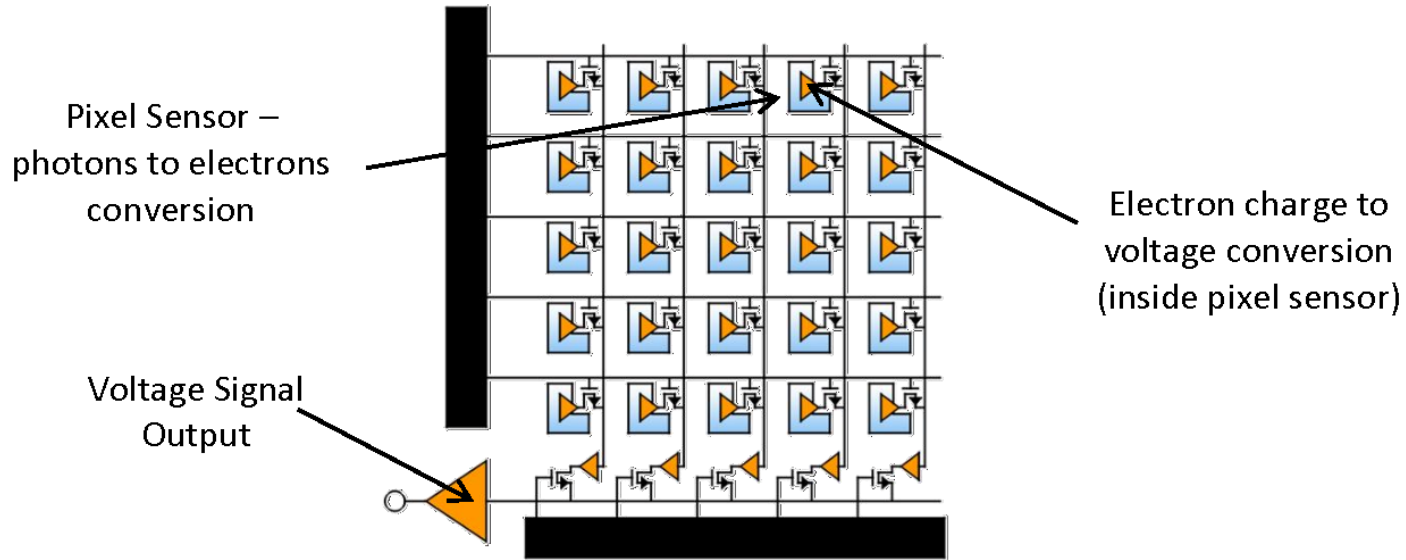

## CMOS (complementary metal-oxide semiconductor)

- each pixel can be read individually (= very fast)
- some space is lost for transistors (= less light sensitive)
- generally more noise (but technology is developing rapidly)
- cheap and very energy efficient

**Ideal for high speed imaging (droplet microfluidics)**

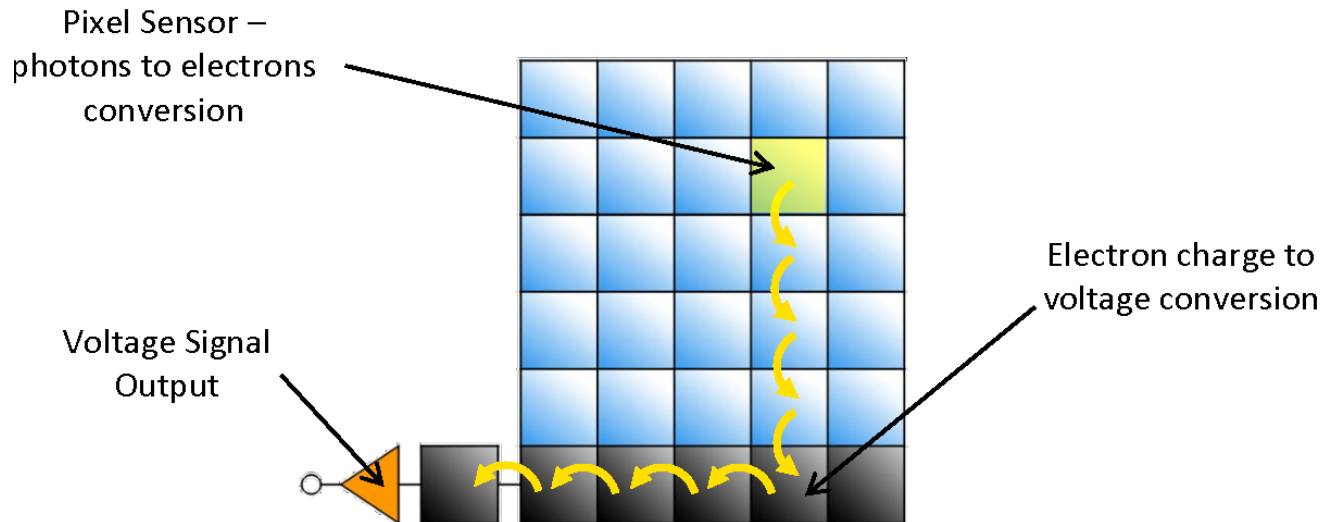

## CCD (charge-coupled device)

- charge is transported across the chip and read at one corner after analog-to-digital conversion (serial pixel readout, = slow)
- very light sensitive
- Expensive & high energy consumption

**Ideal for low light, high content imaging (e.g. fluorescence microscopy)**

# Additional equipment for droplet sorting

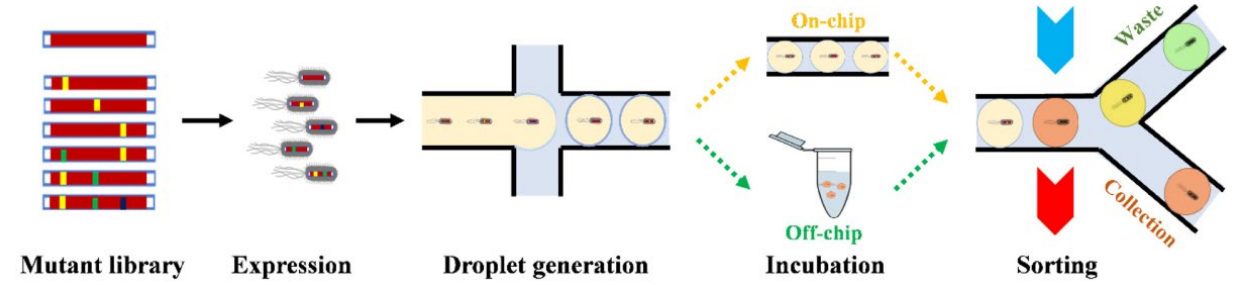
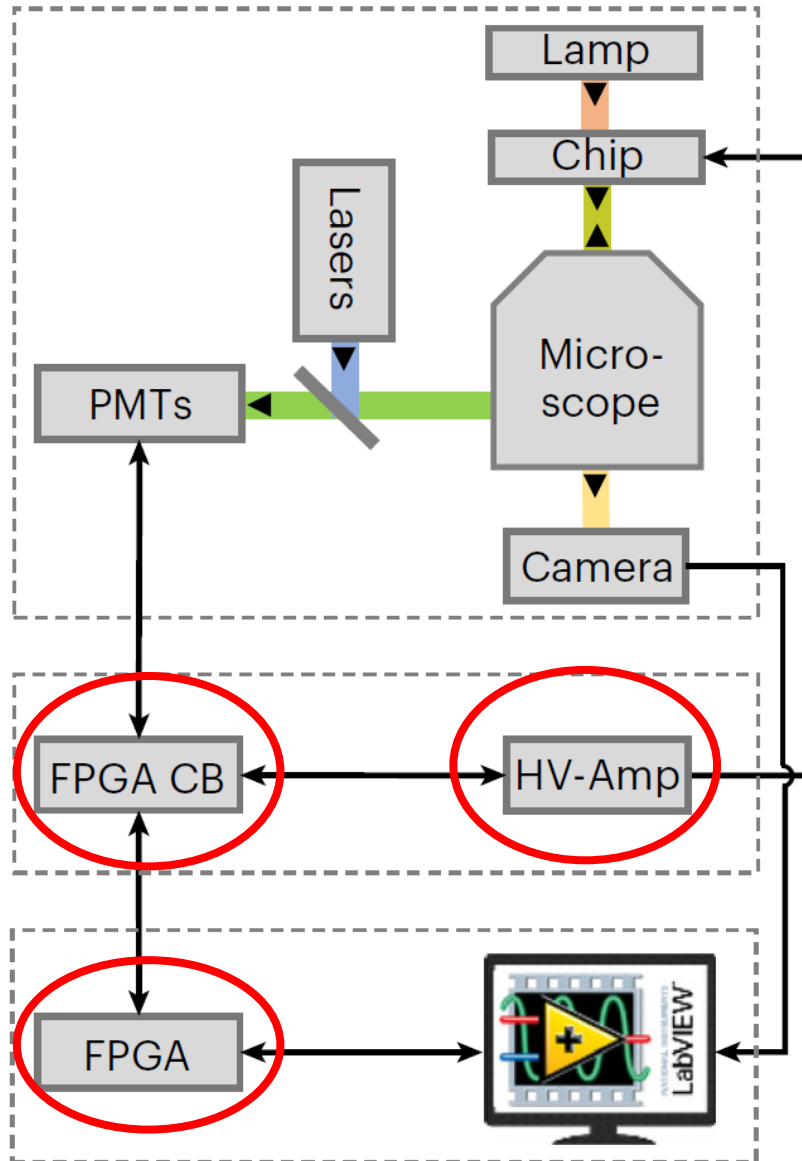

Fu et al., Front. Chem. 9:666867. doi: 10.3389/fchem.2021.666867

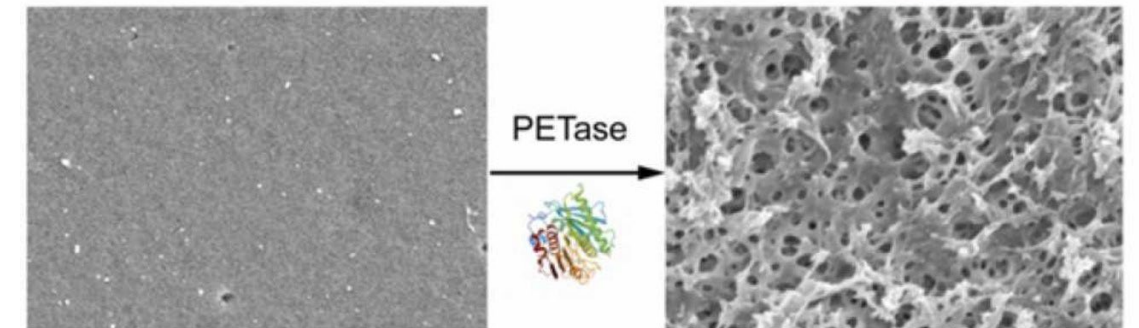
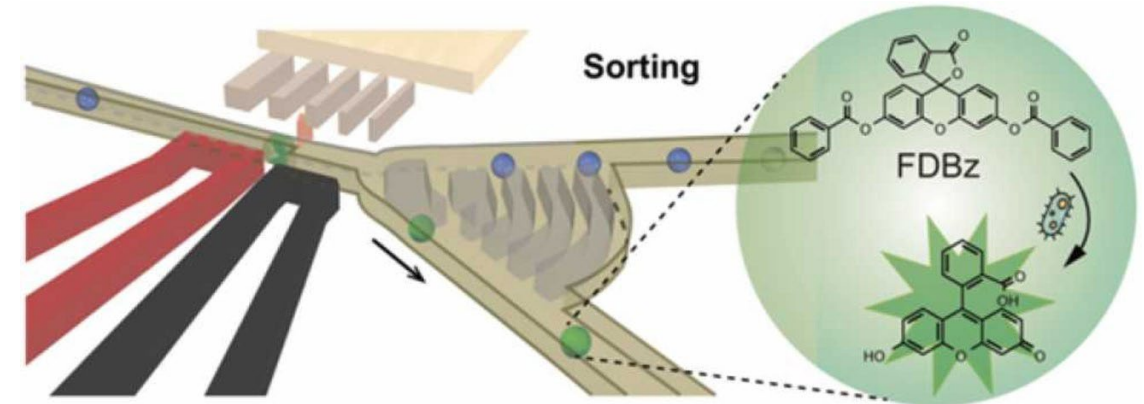

Qiao et al., 2022, <https://doi.org/10.1016/j.jhazmat.2021.127417>

# DEP droplet sorting

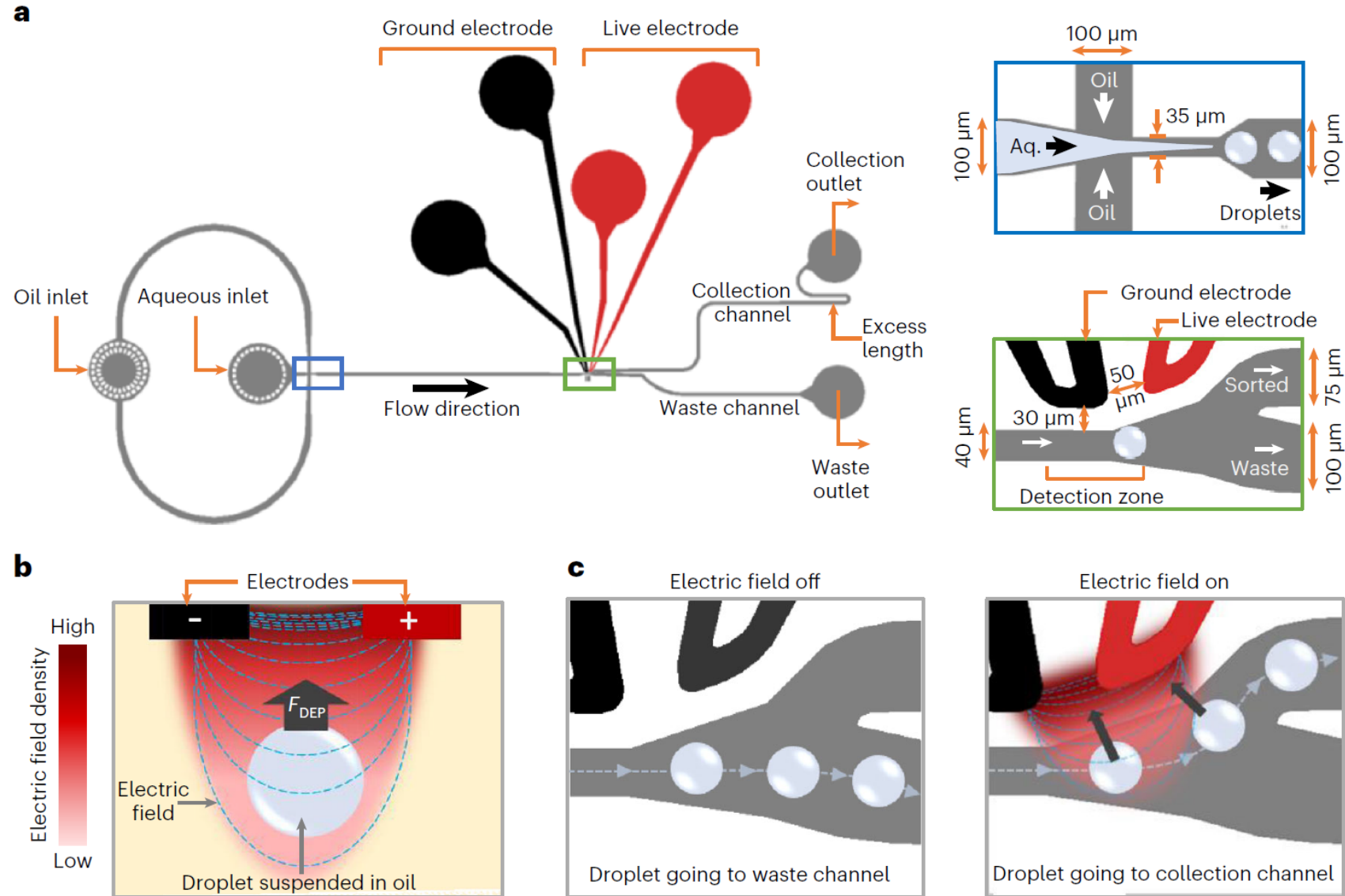

# Approximation of the DEP force

$$F_{DEP} = 2\pi\epsilon_m r^3 \text{Re}(f_{CM})(\nabla|E|^2)$$

$$f_{CM} = \frac{\epsilon_p^* - \epsilon_m^*}{\epsilon_p^* + 2\epsilon_m^*}$$

$$\epsilon_x^* = \epsilon_x \epsilon_0 - j \frac{\sigma_x}{\pi F}$$

$\epsilon$  = relative permittivity of the medium (m) and particle or droplet (p)  
 $r$  = radius of the particle or droplet  
 $\nabla|E|^2$  = gradient of the electrical field square  
 $f_{cm}$  = Clausius-Mossotti factor  
 $\sigma$  = electrical conductivity  
 $j = \sqrt{-1}$  (imaginary number)  
 $F$  = frequency of the AC field

DEP force scales with volume of the particle or droplet and exponentially with field strength

positive (= attractive DEP) if particles or droplets are more polarizable than surrounding medium

changing the AC frequency has an impact

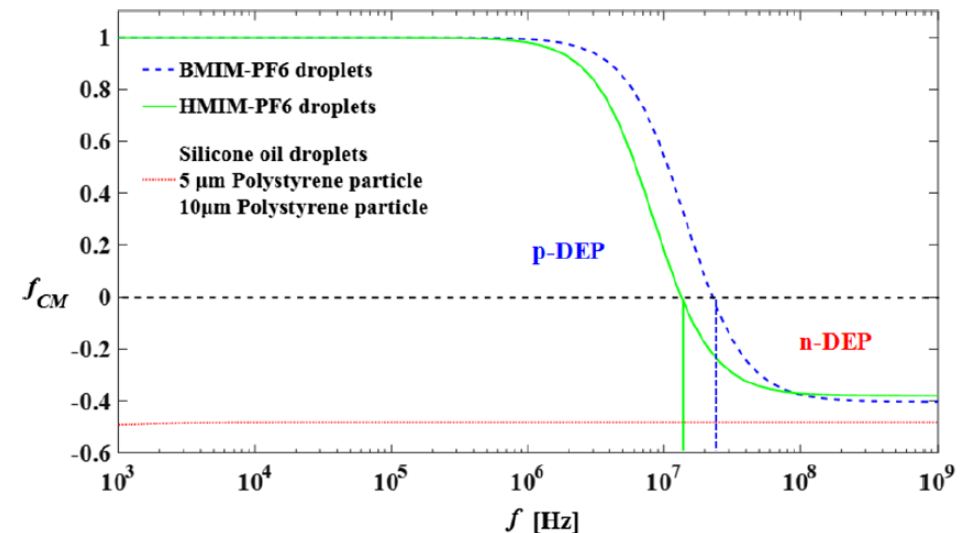

# High voltage amplifier

Simplified Class A amplifier diagram

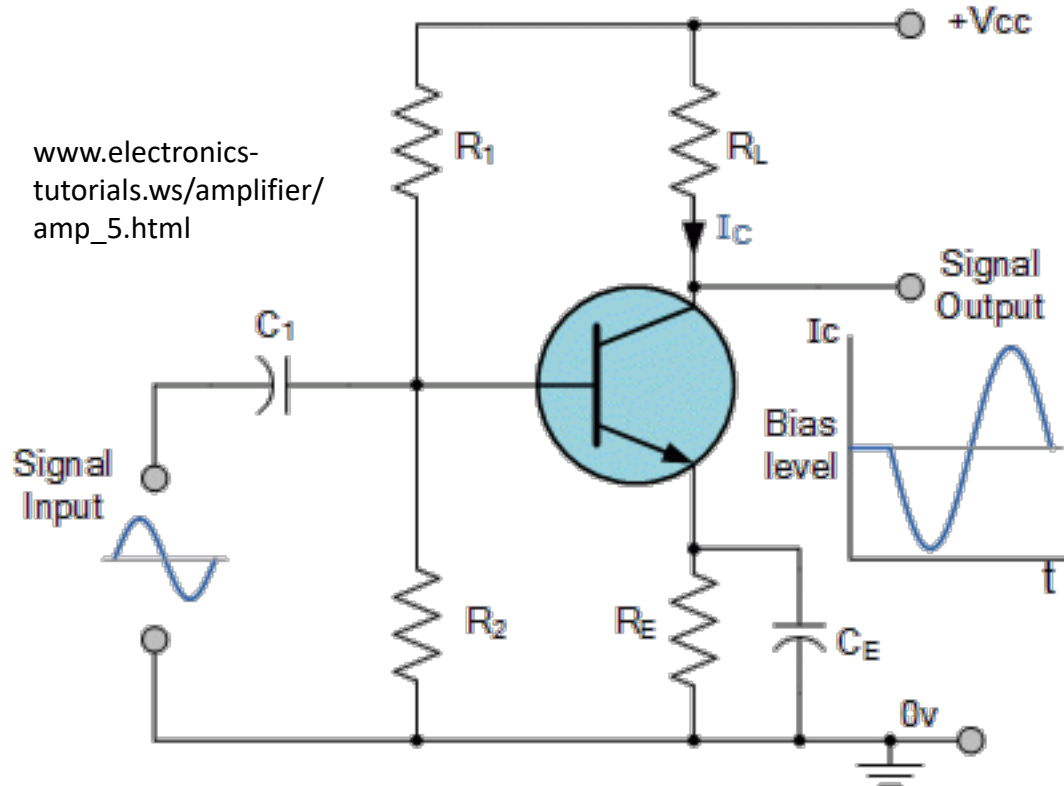

Input 0-2V  
= output signal  
from Nidaq or  
FPGA

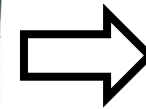
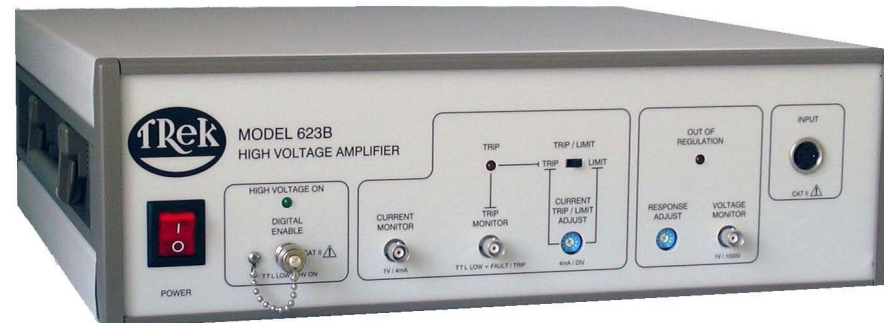
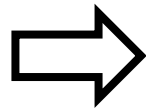

Output 0-2kV (max 40mA, high slew rate)  
= additional LED in your sorting program

# Nidaq vs. FPGA



Nidaq  
(pure connector  
block, no processing)

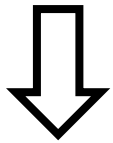

Laptop  
(all signal processing  
and user interaction)

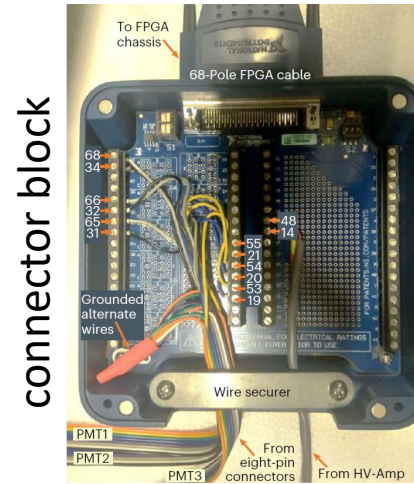

connector block

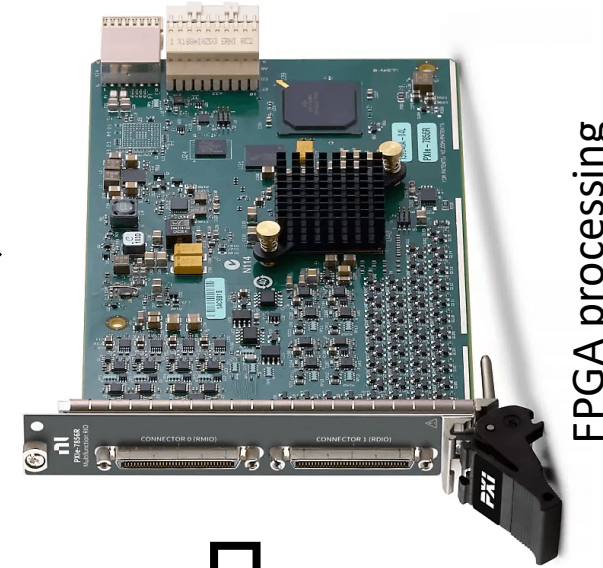
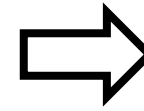

FPGA processing

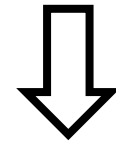

User interaction

# Field Programmable Gate Array (FPGA)

- Basically a **reconfigurable silicon chip** (“field programmable”)
- **Millions of logic gates** can be reconfigured **to execute complex algorithms at very high speed** (200kHz fluorescence data acquisition, function generator, etc.)
- **Parallel processing**
- **Cannot be used to run many different programs**, for each application the FPGA card has to be reconfigured (like changing firmware)



analyzing less than 50 droplets/sec

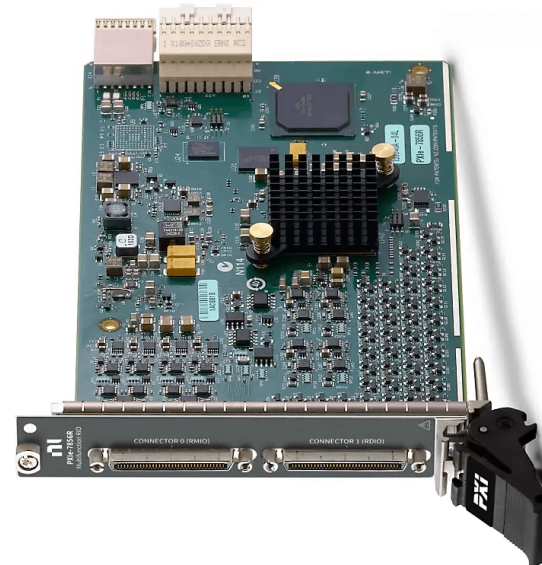

analyzing thousands of droplets/sec

# References

## Datasheets :

- Hamamatsu website
- Tektronix website
- Trek model 623B website

### OVERVIEW

The H11903 series is a photosensor module containing a metal package PMT, a low-power consumption high-voltage power supply circuit, and a low-noise amplifier. The amplifier converts the PMT current output to a voltage output so that signal can be easily processed. Also, the amplifier is connected close to the PMT anode output pin to make the signal less affected by external noise. Six types of products are available with a frequency bandwidth of DC to 200 kHz and different sensitivity characteristics such as spectral response ranges.



### PRODUCT VARIATIONS

Type No.	Spectral response	Photocathode	Window material	Current-to-voltage conversion factor *	Frequency bandwidth *
H11903-110	230 nm to 700 nm	Super bialkali	Borosilicate glass	0.1 V/μA	DC to 200 kHz
H11903-113	185 nm to 700 nm	Super bialkali	UV glass		
H11903-210	230 nm to 700 nm	Ultra bialkali	Borosilicate glass		
H11903-01	230 nm to 870 nm	Multialkali	Borosilicate glass		
H11903-04	185 nm to 870 nm	Multialkali	UV glass		
H11903-20	230 nm to 920 nm	Extended red multialkali	Borosilicate glass		

\* The amplifier specification can be changed upon request. Feel free to contact our sales office. This product can't be used at vacuum environment or reduced pressure environment.

Figure 1: Typical spectral response

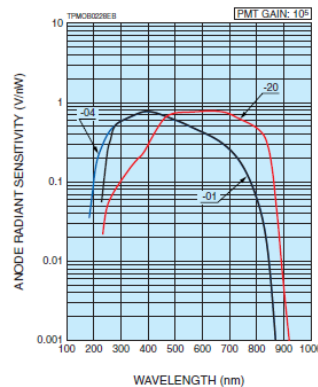
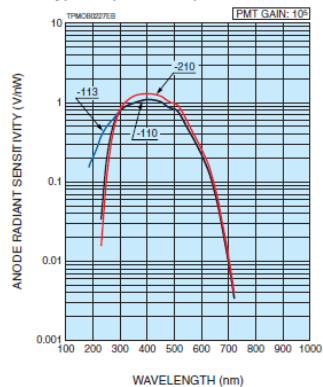

## Schematics :

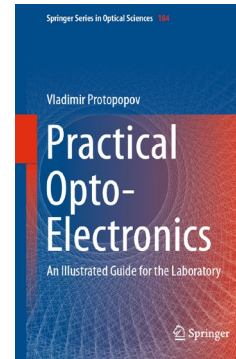

doi: 10.1007/978-3-319-04513-9

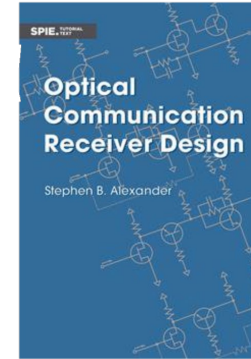

Date Published:  
January 1997  
Pages: 340  
ISBN:  
9780819420237  
Volume: TT22

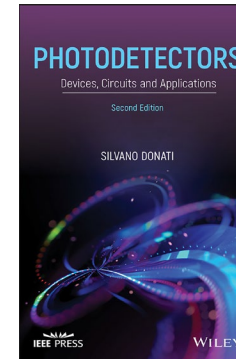

doi:  
10.1002/9781119769958

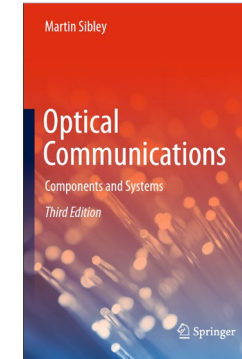

doi : 10.1007/978-3-030-34359-0

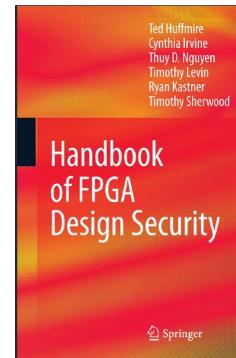

doi:  
10.1007/978-90-481-9157-4

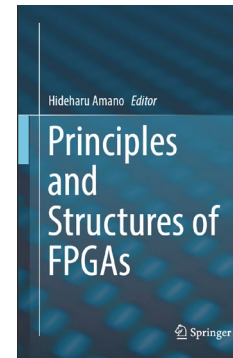

doi:  
10.1007/978-981-13-0824-6

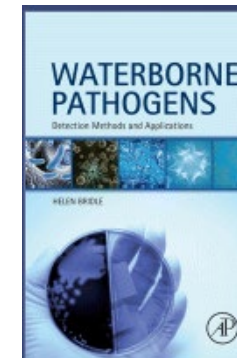

doi:  
10.1016/C2011-0-08797-5

## Papers :

- Panwar *et al.* 2023 Nat. Prot.
- Panwar *et al.* 2023 Lab on Chip
- Rashed *et al.* 2020 Analytical and bioanalytical Chemistry

# Questions?

